

- Power-On Reset Generator
- Automatic Reset Generation After Voltage Drop
- $\overline{\text{RESET}}$ Defined When V_{CC} Exceeds 1 V
- Wide Supply-Voltage Range . . . 3.5 V to 18 V
- Precision Overvoltage and Undervoltage Sensing
- 250-mA Peak Output Current for Driving SCR Gates
- 2-mA Active-Low SCR Gate Drive for False-Trigger Protection
- Temperature-Compensated Voltage Reference
- True and Complementary Reset Outputs
- Externally Adjustable Output Pulse Duration

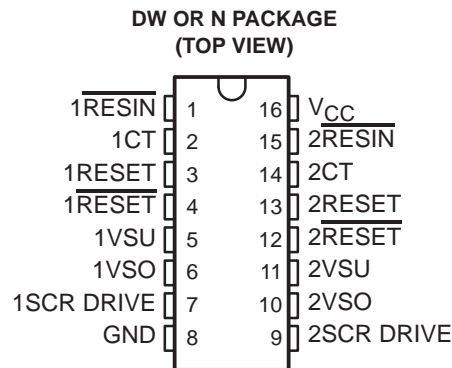

description

The TL7770 is an integrated-circuit system supervisor designed for use as a reset controller in microcomputer and microprocessor power-supply systems. This device contains two independent supply-voltage supervisors that monitor the supplies for overvoltage and undervoltage conditions at the VSO and VSU terminals, respectively. When V_{CC} attains the minimum voltage of 1 V during power up, the $\overline{\text{RESET}}$ output becomes active (low). As V_{CC} approaches 3.5 V, the time-delay function activates, latching RESET and $\overline{\text{RESET}}$ active (high and low, respectively) for a time delay (t_d) after system voltages have achieved normal levels. Above $V_{CC} = 3.5$ V, taking $\overline{\text{RESIN}}$ low activates the time-delay function during normal system-voltage levels. To ensure that the microcomputer system has reset, the outputs remain active until the voltage at VSU exceeds the threshold value, V_{IT+} , for a time delay, which is determined by an external timing capacitor such that:

$$t_d \approx 20 \times 10^3 \times \text{capacitance}$$

where t_d is in seconds and capacitance is in farads.

The overvoltage-detection circuit is programmable for a wide range of designs. During an overvoltage condition, an internal silicon-controlled rectifier (SCR) is triggered, providing 250-mA peak instantaneous current and 25-mA continuous current to the SCR gate drive terminal, which can drive an external high-current SCR gate or an overvoltage-warning circuit.

The TL7770C series is characterized for operation from 0°C to 70°C. The TL7770I series is characterized for operation from -40°C to 85°C.



Please be aware that an important notice concerning availability, standard warranty, and use in critical applications of Texas Instruments semiconductor products and disclaimers thereto appears at the end of this data sheet.

TL7770-5, TL7770-12 DUAL POWER-SUPPLY SUPERVISORS

SLVS019F – OCTOBER 1987 – REVISED JULY 1999

AVAILABLE OPTIONS

T _A	PACKAGED DEVICES		CHIP FORM (Y)
	SMALL OUTLINE (DW)	PLASTIC DIP (N)	
0°C to 70°C	TL7770-5CDW TL7770-12CDW	TL7770-5CN TL7770-12CN	TL7770-5Y TL7770-12Y
-40°C to 85°C	TL7770-5IDW	TL7770-5IN	—

DW package is available taped and reeled. Add the suffix R to the device type (e.g., TL7770-5CDWR). Chip forms are tested at 25°C.

functional block diagram (each channel)

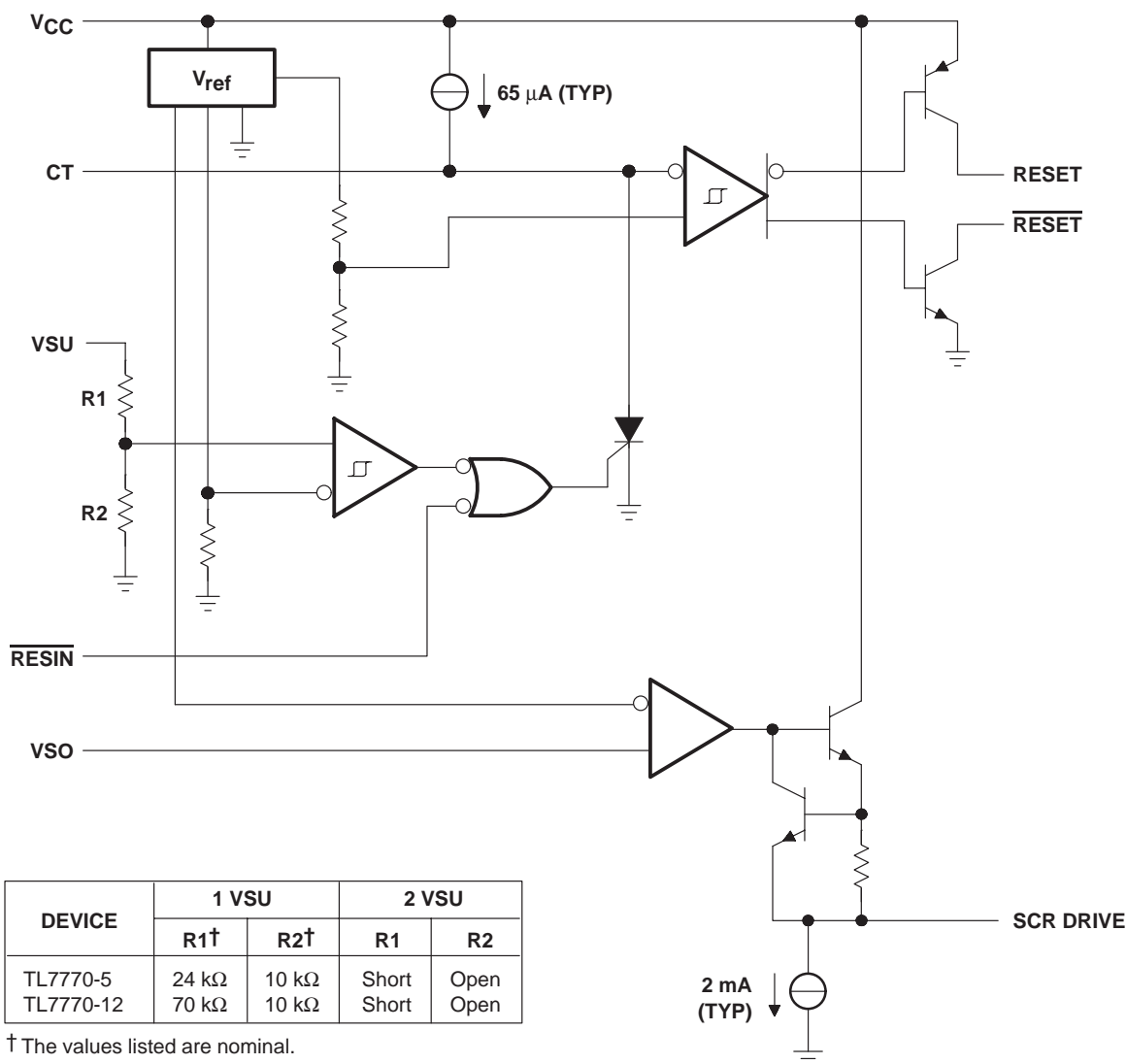

timing requirements

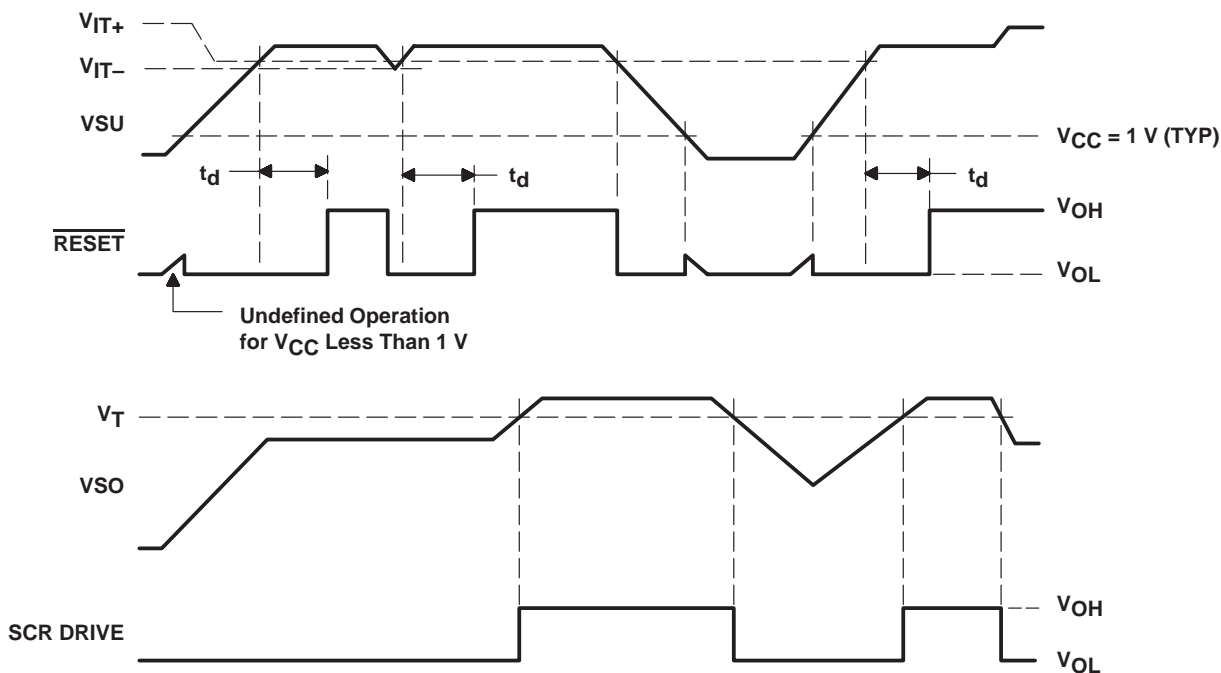

absolute maximum ratings over operating free-air temperature range (unless otherwise noted)[†]

Supply voltage, V_{CC} (see Note 1)	20 V
Input voltage range, V_I : $1V_{SU}$, $2V_{SU}$, $1V_{SO}$, and $2V_{SO}$ (see Note 1)	-0.3 V to 18 V
Low-level output current ($1\overline{\text{RESET}}$ and $2\overline{\text{RESET}}$), I_{OL}	20 mA
High-level output current ($1\overline{\text{RESET}}$ and $2\overline{\text{RESET}}$), I_{OH}	-20 mA
Package thermal impedance, θ_{JA} (see Notes 2 and 3): DW package	57°C/W
N package	88°C/W
Lead temperature 1,6 mm (1/16 in) from case for 10 seconds: DW or N package	260°C
Storage temperature range, T_{stg}	-65°C to 150°C

[†] Stresses beyond those listed under "absolute maximum ratings" may cause permanent damage to the device. These are stress ratings only, and functional operation of the device at these or any other conditions beyond those indicated under "recommended operating conditions" is not implied. Exposure to absolute-maximum-rated conditions for extended periods may affect device reliability.

- NOTES:
- All voltage values are with respect to the network ground terminal.
 - Maximum power dissipation is a function of $T_J(\text{max})$, θ_{JA} , and T_A . The maximum allowable power dissipation at any allowable ambient temperature is $P_D = (T_J(\text{max}) - T_A)/\theta_{JA}$. Operating at the absolute maximum T_J of 150°C can impact reliability.
 - The package thermal impedance is calculated in accordance with JESD 51, except for through-hole packages, which use a trace length of zero.

TL7770-5, TL7770-12 DUAL POWER-SUPPLY SUPERVISORS

SLVS019F – OCTOBER 1987 – REVISED JULY 1999

recommended operating conditions

		MIN	MAX	UNIT
Supply voltage, V_{CC}		3.5	18	V
Input voltage range, V_I (see Note 4)	1VSU, 2VSU, 2VSO, 1VSO	0	18	V
Output voltage, V_O (1CT, 2CT)			5	V
High-level input voltage range, V_{IH} (1RESIN, 2RESIN)		2	18	V
Low-level input voltage range, V_{IL} (1RESIN, 2RESIN)		0	0.8	V
Output sink current, I_O (1CT, 2CT)			50	μ A
High-level output current, I_{OH} (1RESET, 2RESET)			-16	mA
Low-level output current, I_{OL} (1RESET, 2RESET)			16	mA
Continuous output current, I_O (1SCR DRIVE, 2SCR DRIVE)			25	mA
Timing capacitor, C_T			10	μ F
Operating free-air temperature, T_A	TL7770C series	0	70	$^{\circ}$ C
	TL7770I series	-40	85	$^{\circ}$ C

NOTE 4: The algebraic convention, in which the least positive (most negative) value is designated minimum, is used in this data sheet for logic voltage levels only.



electrical characteristics over recommended operating conditions (unless otherwise noted)

supply supervisor section

PARAMETER		TEST CONDITION [†]	TL7770-5C TL7770-12C TL7770-5I			UNIT
			MIN	TYP [‡]	MAX	
V _{OH}	High-level output voltage	RESET	I _{OH} = -15 mA			V
		SCR DRIVE	I _{OH} = -20 mA			
V _{OL}	Low-level output voltage	RESET	I _{OL} = 15 mA			V
V _{IT-}	Undervoltage input threshold at VSU (negative-going)	TL7770-5 (5-V sense, 1VSU)	T _A = MIN to MAX			V
		TL7770-12 (12-V sense, 1VSU)				
		TL7770-5, TL7770-12 (programmable sense, 2VSU)				
V _{hys}	Hysteresis at VSU (V _{IT+} - V _{IT-})	TL7770-5 (5-V sense, 1VSU)	T _A = MIN to MAX			mV
		TL7770-12 (12-V sense, 1VSU)				
		TL7770-5, TL7770-12 (programmable sense, 2VSU)				
V _T	Overshoot threshold at VSO	TL7770-5, TL7770-12 (VSO)	T _A = MIN to MAX			V
I _I	Input current	RESIN	V _I = 5.5 V or 0.4 V			μA
		VSO	V _I = 2.4 V			
I _{OH}	High-level output current	RESET	V _O = 18 V			μA
I _{OL}	Low-level output current	RESET	V _O = 0			μA
I _{OH}	Peak output current	SCR DRIVE	Duration = 1 ms			mA

[†] For conditions shown as MIN or MAX, use the appropriate value specified in the recommended operating conditions.

[‡] Typical values are at V_{CC} = 5 V, T_A = 25°C.

total device

PARAMETER		TEST CONDITION [†]	TL7770-5C TL7770-12C TL7770-5I			UNIT
			MIN	TYP [‡]	MAX	
V _{res} [§]	Power-up reset voltage	V _{CC} = VSU	T _A = 25°C			V
I _{CC}	Supply current	1VSU = 18 V, 2VSU = 2 V, 1RESIN and 2RESIN at V _{CC} , 1VSO and 2VSO at 0 V	T _A = 25°C			mA
			T _A = MIN to MAX			

[†] For conditions shown as MIN or MAX, use the appropriate value specified in the recommended operating conditions.

[‡] Typical values are at V_{CC} = 5 V, T_A = 25°C.

[§] This is the lowest voltage at which RESET becomes active.

TL7770-5, TL7770-12 DUAL POWER-SUPPLY SUPERVISORS

SLVS019F – OCTOBER 1987 – REVISED JULY 1999

electrical characteristics over recommended operating conditions (unless otherwise noted)

supply supervisor section

PARAMETER		TEST CONDITIONS	TL7770-5Y TL7770-12Y			UNIT
			MIN	TYP†	MAX	
V _{IT-}	Undervoltage input threshold at VSU (negative-going)	TL7770-5 (5-V sense, 1VSU)	T _A = MIN to MAX	4.46	4.64	V
		TL7770-12 (12-V sense, 1VSU)		10.68	11.12	
		TL7770-5, TL7770-12 (programmable sense, 2VSU)		1.47	1.53	
V _{hys}	Hysteresis at VSU (V _{IT+} - V _{IT-})	TL7770-5 (5-V sense, 1VSU)	T _A = MIN to MAX	15		mV
		TL7770-12 (12-V sense, 1VSU)		36		
		TL7770-5, TL7770-12 (programmable sense, 2VSU)		5		
V _T	Overvoltage threshold at VSO	TL7770-5, TL7770-12 (VSO)	T _A = MIN to MAX	2.48	2.68	V
I _I	Input current	VSO	V _I = 2.4 V	0.5		μA

† Typical values are at V_{CC} = 5 V, T_A = 25°C.

total device

PARAMETER	TEST CONDITIONS	TL7770-5Y TL7770-12Y			UNIT
		MIN	TYP†	MAX	
V _{res} ‡	Power-up reset voltage	V _{CC} = VSU, V _{OL} = 0.4 V, I _{OL} = 1 mA		0.8	V
I _{CC}	Supply current	1VSU = 18 V, 2VSU = 2 V, 1RESIN and 2RESIN at V _{CC} , 1VSO and 2VSO at 0 V	T _A = 25°C	5	mA

† Typical values are at V_{CC} = 5 V, T_A = 25°C.

‡ This is the lowest voltage at which RESET becomes active.

switching characteristics, V_{CC} = 5 V, C_T open, T_A = 25°C

PARAMETER		FROM (INPUT)	TO (OUTPUT)	TEST CONDITIONS	MIN	TYP	MAX	UNIT
t _{PLH}	Propagation delay time, low-to-high-level output	RESIN	RESET	See Figures 1 and 3		270	500	ns
t _{PHL}	Propagation delay time, high-to-low-level output	RESIN	RESET			270	500	ns
t _r	Rise time		RESET				75	ns
t _f	Fall time		RESET			150		
t _r	Rise time		RESET				75	ns
t _f	Fall time		RESET				50	
t _{w(min)}	Minimum effective pulse duration	RESIN		See Figure 2a		150	ns	
		VSU		See Figure 2b		100		



PARAMETER MEASUREMENT INFORMATION

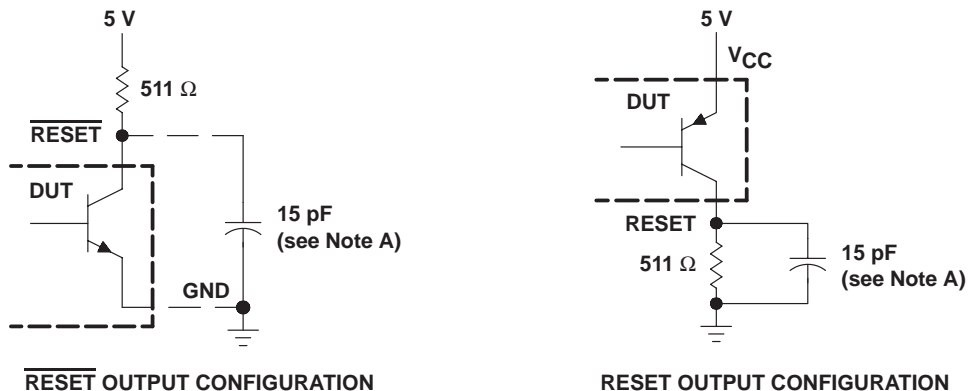

NOTE A: This includes jig and probe capacitance.

Figure 1. $\overline{\text{RESET}}$ and RESET Output Configurations

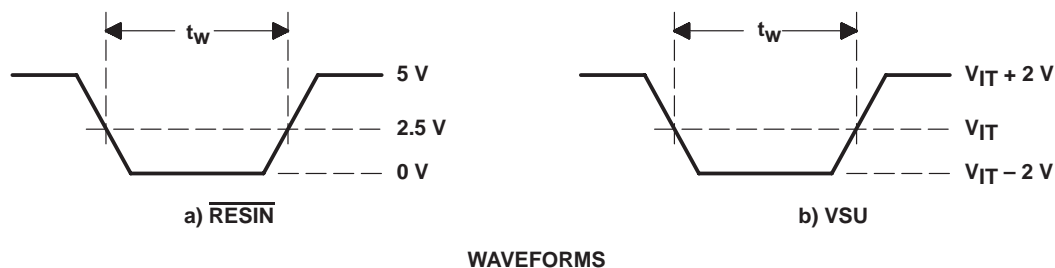

WAVEFORMS

Figure 2. Input Pulse Definition

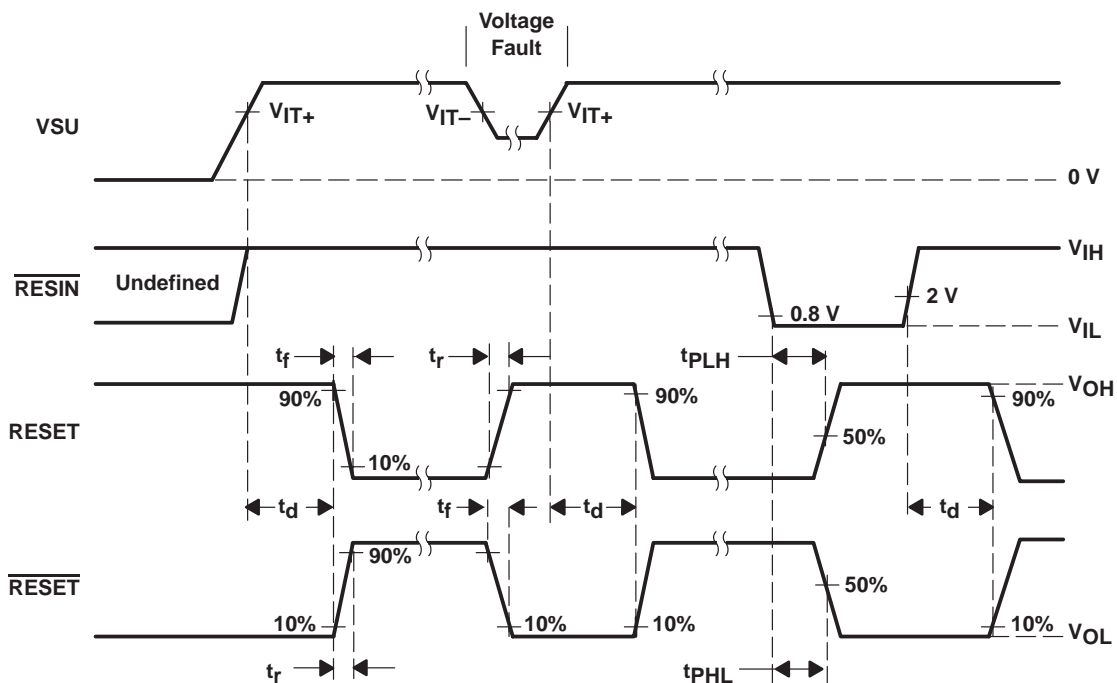
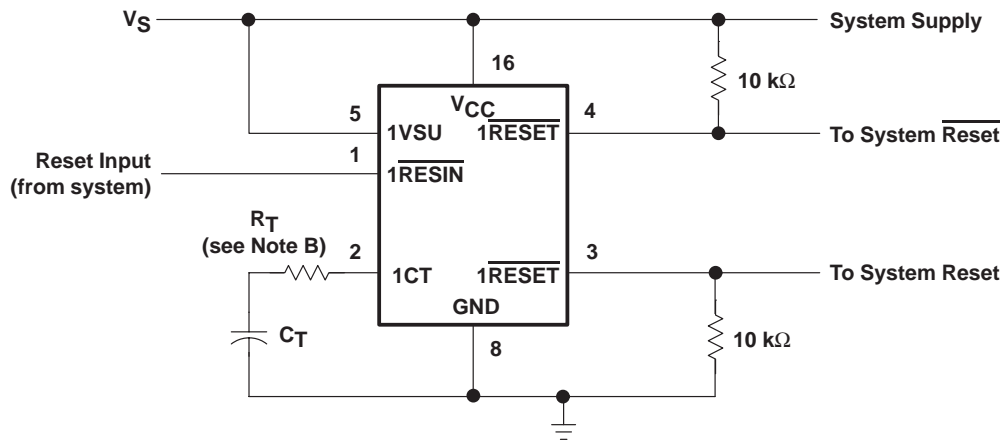

Figure 3. Voltage Waveforms

TL7770-5, TL7770-12 DUAL POWER-SUPPLY SUPERVISORS

SLVS019F – OCTOBER 1987 – REVISED JULY 1999

APPLICATION INFORMATION



NOTE B: When V_{CC} and 1VSU are connected to the same point, it is recommended that series resistance (R_T) be added between the time-delay programming capacitor (C_T) and the voltage-supervisor device terminal (1CT). The suggested R_T value is given by:

$$R_T > \frac{V_I - V_{T-}}{1 \times 10^{-3}}, \text{ where } V_I = (\text{the lesser of } 7.1 \text{ V or } V_S)$$

When this series resistor is used, the t_d calculation is as follows:

$$t_d = \frac{1.3 - [(6.5E - 5) \times 10^{-5}] \times R_T}{6.5 \times 10^{-5}} \times C_T$$

Figure 4. System Reset Controller With Undervoltage Sensing

PACKAGING INFORMATION

Orderable Device	Status ⁽¹⁾	Package Type	Package Drawing	Pins	Package Qty	Eco Plan ⁽²⁾	Lead/Ball Finish	MSL Peak Temp ⁽³⁾
5962-9093201MEA	OBSOLETE	CDIP	J	16		TBD	Call TI	Call TI
5962-9093202M2A	OBSOLETE	LCCC	FK	20		TBD	Call TI	Call TI
5962-9093202MEA	OBSOLETE	CDIP	J	16		TBD	Call TI	Call TI
TL7770-12CDW	ACTIVE	SOIC	DW	16	40	Green (RoHS & no Sb/Br)	CU NIPDAU	Level-1-260C-UNLIM
TL7770-12CDWE4	ACTIVE	SOIC	DW	16	40	Green (RoHS & no Sb/Br)	CU NIPDAU	Level-1-260C-UNLIM
TL7770-12CDWG4	ACTIVE	SOIC	DW	16	40	Green (RoHS & no Sb/Br)	CU NIPDAU	Level-1-260C-UNLIM
TL7770-12CDWR	ACTIVE	SOIC	DW	16	2000	Green (RoHS & no Sb/Br)	CU NIPDAU	Level-1-260C-UNLIM
TL7770-12CDWRE4	ACTIVE	SOIC	DW	16	2000	Green (RoHS & no Sb/Br)	CU NIPDAU	Level-1-260C-UNLIM
TL7770-12CDWRG4	ACTIVE	SOIC	DW	16	2000	Green (RoHS & no Sb/Br)	CU NIPDAU	Level-1-260C-UNLIM
TL7770-12CN	OBSOLETE	PDIP	N	16		TBD	Call TI	Call TI
TL7770-12MJB	OBSOLETE	CDIP	J	16		TBD	Call TI	Call TI
TL7770-5CDW	ACTIVE	SOIC	DW	16	40	Green (RoHS & no Sb/Br)	CU NIPDAU	Level-1-260C-UNLIM
TL7770-5CDWE4	ACTIVE	SOIC	DW	16	40	Green (RoHS & no Sb/Br)	CU NIPDAU	Level-1-260C-UNLIM
TL7770-5CDWG4	ACTIVE	SOIC	DW	16	40	Green (RoHS & no Sb/Br)	CU NIPDAU	Level-1-260C-UNLIM
TL7770-5CDWR	ACTIVE	SOIC	DW	16	2000	Green (RoHS & no Sb/Br)	CU NIPDAU	Level-1-260C-UNLIM
TL7770-5CDWRE4	ACTIVE	SOIC	DW	16	2000	Green (RoHS & no Sb/Br)	CU NIPDAU	Level-1-260C-UNLIM
TL7770-5CDWRG4	ACTIVE	SOIC	DW	16	2000	Green (RoHS & no Sb/Br)	CU NIPDAU	Level-1-260C-UNLIM
TL7770-5CN	ACTIVE	PDIP	N	16	25	Pb-Free (RoHS)	CU NIPDAU	N / A for Pkg Type
TL7770-5CNE4	ACTIVE	PDIP	N	16	25	Pb-Free (RoHS)	CU NIPDAU	N / A for Pkg Type
TL7770-5IDW	ACTIVE	SOIC	DW	16	40	Green (RoHS & no Sb/Br)	CU NIPDAU	Level-1-260C-UNLIM
TL7770-5IDWE4	ACTIVE	SOIC	DW	16	40	Green (RoHS & no Sb/Br)	CU NIPDAU	Level-1-260C-UNLIM
TL7770-5IDWG4	ACTIVE	SOIC	DW	16	40	Green (RoHS & no Sb/Br)	CU NIPDAU	Level-1-260C-UNLIM
TL7770-5IDWR	ACTIVE	SOIC	DW	16	2000	Green (RoHS & no Sb/Br)	CU NIPDAU	Level-1-260C-UNLIM
TL7770-5IDWRE4	ACTIVE	SOIC	DW	16	2000	Green (RoHS & no Sb/Br)	CU NIPDAU	Level-1-260C-UNLIM
TL7770-5IDWRG4	ACTIVE	SOIC	DW	16	2000	Green (RoHS & no Sb/Br)	CU NIPDAU	Level-1-260C-UNLIM
TL7770-5MFKB	OBSOLETE	LCCC	FK	20		TBD	Call TI	Call TI
TL7770-5MJB	OBSOLETE	CDIP	J	16		TBD	Call TI	Call TI
TL7770-5QDW	OBSOLETE	SOIC	DW	16		TBD	Call TI	Call TI

Orderable Device	Status ⁽¹⁾	Package Type	Package Drawing	Pins	Package Qty	Eco Plan ⁽²⁾	Lead/Ball Finish	MSL Peak Temp ⁽³⁾
TL7770-5QDWR	OBSOLETE	SOIC	DW	16		TBD	Call TI	Call TI
TL7770-5QN	OBSOLETE	PDIP	N	16		TBD	Call TI	Call TI

⁽¹⁾ The marketing status values are defined as follows:

ACTIVE: Product device recommended for new designs.

LIFEBUY: TI has announced that the device will be discontinued, and a lifetime-buy period is in effect.

NRND: Not recommended for new designs. Device is in production to support existing customers, but TI does not recommend using this part in a new design.

PREVIEW: Device has been announced but is not in production. Samples may or may not be available.

OBSOLETE: TI has discontinued the production of the device.

⁽²⁾ Eco Plan - The planned eco-friendly classification: Pb-Free (RoHS), Pb-Free (RoHS Exempt), or Green (RoHS & no Sb/Br) - please check <http://www.ti.com/productcontent> for the latest availability information and additional product content details.

TBD: The Pb-Free/Green conversion plan has not been defined.

Pb-Free (RoHS): TI's terms "Lead-Free" or "Pb-Free" mean semiconductor products that are compatible with the current RoHS requirements for all 6 substances, including the requirement that lead not exceed 0.1% by weight in homogeneous materials. Where designed to be soldered at high temperatures, TI Pb-Free products are suitable for use in specified lead-free processes.

Pb-Free (RoHS Exempt): This component has a RoHS exemption for either 1) lead-based flip-chip solder bumps used between the die and package, or 2) lead-based die adhesive used between the die and leadframe. The component is otherwise considered Pb-Free (RoHS compatible) as defined above.

Green (RoHS & no Sb/Br): TI defines "Green" to mean Pb-Free (RoHS compatible), and free of Bromine (Br) and Antimony (Sb) based flame retardants (Br or Sb do not exceed 0.1% by weight in homogeneous material)

⁽³⁾ MSL, Peak Temp. -- The Moisture Sensitivity Level rating according to the JEDEC industry standard classifications, and peak solder temperature.

Important Information and Disclaimer: The information provided on this page represents TI's knowledge and belief as of the date that it is provided. TI bases its knowledge and belief on information provided by third parties, and makes no representation or warranty as to the accuracy of such information. Efforts are underway to better integrate information from third parties. TI has taken and continues to take reasonable steps to provide representative and accurate information but may not have conducted destructive testing or chemical analysis on incoming materials and chemicals. TI and TI suppliers consider certain information to be proprietary, and thus CAS numbers and other limited information may not be available for release.

In no event shall TI's liability arising out of such information exceed the total purchase price of the TI part(s) at issue in this document sold by TI to Customer on an annual basis.

TAPE AND REEL INFORMATION

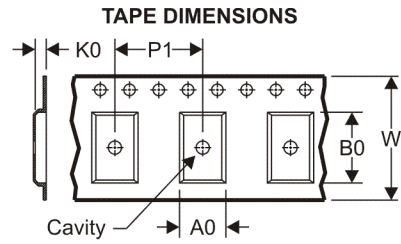
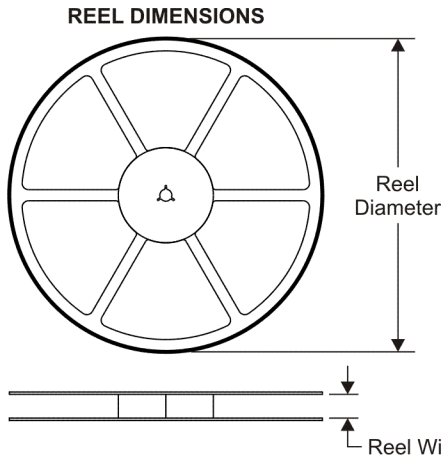

A0	Dimension designed to accommodate the component width
B0	Dimension designed to accommodate the component length
K0	Dimension designed to accommodate the component thickness
W	Overall width of the carrier tape
P1	Pitch between successive cavity centers

QUADRANT ASSIGNMENTS FOR PIN 1 ORIENTATION IN TAPE

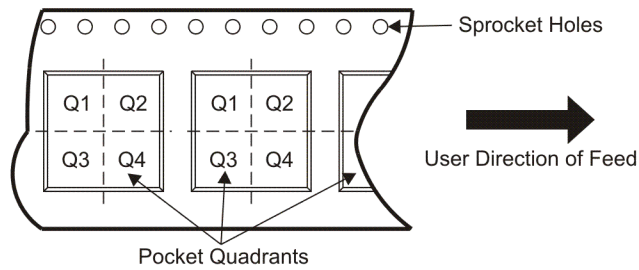

*All dimensions are nominal

Device	Package Type	Package Drawing	Pins	SPQ	Reel Diameter (mm)	Reel Width W1 (mm)	A0 (mm)	B0 (mm)	K0 (mm)	P1 (mm)	W (mm)	Pin1 Quadrant
TL7770-12CDWR	SOIC	DW	16	2000	330.0	16.4	10.75	10.7	2.7	12.0	16.0	Q1
TL7770-5CDWR	SOIC	DW	16	2000	330.0	16.4	10.75	10.7	2.7	12.0	16.0	Q1
TL7770-5IDWR	SOIC	DW	16	2000	330.0	16.4	10.75	10.7	2.7	12.0	16.0	Q1

TAPE AND REEL BOX DIMENSIONS



*All dimensions are nominal

Device	Package Type	Package Drawing	Pins	SPQ	Length (mm)	Width (mm)	Height (mm)
TL7770-12CDWR	SOIC	DW	16	2000	346.0	346.0	33.0
TL7770-5CDWR	SOIC	DW	16	2000	346.0	346.0	33.0
TL7770-5IDWR	SOIC	DW	16	2000	346.0	346.0	33.0

J (R-GDIP-T**)

14 LEADS SHOWN

CERAMIC DUAL IN-LINE PACKAGE



DIM \ PINS **	14	16	18	20
A	0.300 (7,62) BSC	0.300 (7,62) BSC	0.300 (7,62) BSC	0.300 (7,62) BSC
B MAX	0.785 (19,94)	.840 (21,34)	0.960 (24,38)	1.060 (26,92)
B MIN	—	—	—	—
C MAX	0.300 (7,62)	0.300 (7,62)	0.310 (7,87)	0.300 (7,62)
C MIN	0.245 (6,22)	0.245 (6,22)	0.220 (5,59)	0.245 (6,22)



4040083/F 03/03

- NOTES:
- All linear dimensions are in inches (millimeters).
 - This drawing is subject to change without notice.
 - This package is hermetically sealed with a ceramic lid using glass frit.
 - Index point is provided on cap for terminal identification only on press ceramic glass frit seal only.
 - Falls within MIL STD 1835 GDIP1-T14, GDIP1-T16, GDIP1-T18 and GDIP1-T20.

FK (S-CQCC-N**)

LEADLESS CERAMIC CHIP CARRIER

28 TERMINAL SHOWN



4040140/D 10/96

- NOTES:
- A. All linear dimensions are in inches (millimeters).
 - B. This drawing is subject to change without notice.
 - C. This package can be hermetically sealed with a metal lid.
 - D. The terminals are gold plated.
 - E. Falls within JEDEC MS-004

DW (R-PDSO-G16)

PLASTIC SMALL-OUTLINE PACKAGE

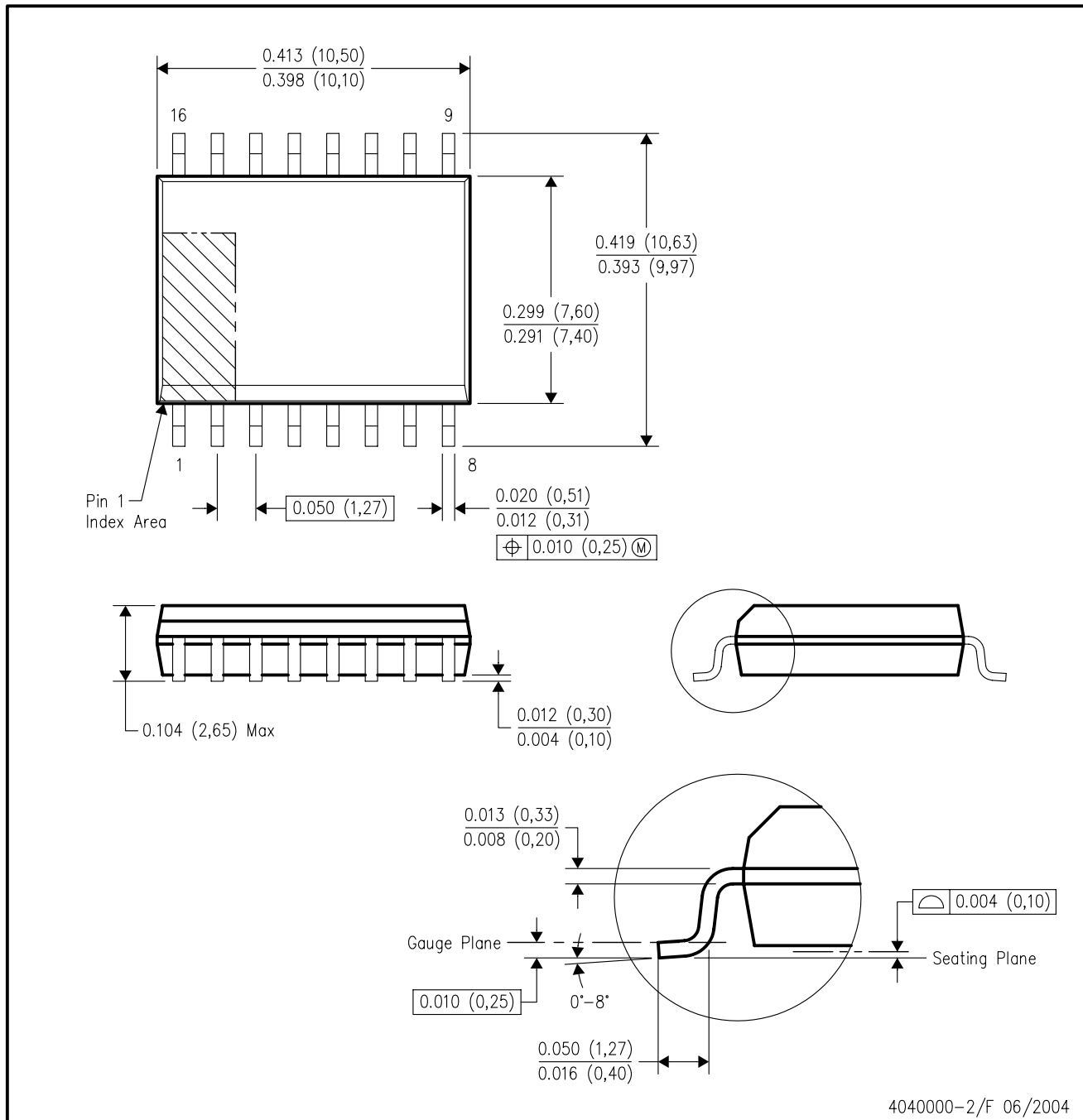

4040000-2/F 06/2004

- NOTES:
- A. All linear dimensions are in inches (millimeters).
 - B. This drawing is subject to change without notice.
 - C. Body dimensions do not include mold flash or protrusion not to exceed 0.006 (0,15).
 - D. Falls within JEDEC MS-013 variation AA.

N (R-PDIP-T**)

PLASTIC DUAL-IN-LINE PACKAGE

16 PINS SHOWN



- NOTES:
- A. All linear dimensions are in inches (millimeters).
 - B. This drawing is subject to change without notice.
 - Falls within JEDEC MS-001, except 18 and 20 pin minimum body length (Dim A).
 - The 20 pin end lead shoulder width is a vendor option, either half or full width.

IMPORTANT NOTICE

Texas Instruments Incorporated and its subsidiaries (TI) reserve the right to make corrections, modifications, enhancements, improvements, and other changes to its products and services at any time and to discontinue any product or service without notice. Customers should obtain the latest relevant information before placing orders and should verify that such information is current and complete. All products are sold subject to TI's terms and conditions of sale supplied at the time of order acknowledgment.

TI warrants performance of its hardware products to the specifications applicable at the time of sale in accordance with TI's standard warranty. Testing and other quality control techniques are used to the extent TI deems necessary to support this warranty. Except where mandated by government requirements, testing of all parameters of each product is not necessarily performed.

TI assumes no liability for applications assistance or customer product design. Customers are responsible for their products and applications using TI components. To minimize the risks associated with customer products and applications, customers should provide adequate design and operating safeguards.

TI does not warrant or represent that any license, either express or implied, is granted under any TI patent right, copyright, mask work right, or other TI intellectual property right relating to any combination, machine, or process in which TI products or services are used. Information published by TI regarding third-party products or services does not constitute a license from TI to use such products or services or a warranty or endorsement thereof. Use of such information may require a license from a third party under the patents or other intellectual property of the third party, or a license from TI under the patents or other intellectual property of TI.

Reproduction of TI information in TI data books or data sheets is permissible only if reproduction is without alteration and is accompanied by all associated warranties, conditions, limitations, and notices. Reproduction of this information with alteration is an unfair and deceptive business practice. TI is not responsible or liable for such altered documentation. Information of third parties may be subject to additional restrictions.

Resale of TI products or services with statements different from or beyond the parameters stated by TI for that product or service voids all express and any implied warranties for the associated TI product or service and is an unfair and deceptive business practice. TI is not responsible or liable for any such statements.

TI products are not authorized for use in safety-critical applications (such as life support) where a failure of the TI product would reasonably be expected to cause severe personal injury or death, unless officers of the parties have executed an agreement specifically governing such use. Buyers represent that they have all necessary expertise in the safety and regulatory ramifications of their applications, and acknowledge and agree that they are solely responsible for all legal, regulatory and safety-related requirements concerning their products and any use of TI products in such safety-critical applications, notwithstanding any applications-related information or support that may be provided by TI. Further, Buyers must fully indemnify TI and its representatives against any damages arising out of the use of TI products in such safety-critical applications.

TI products are neither designed nor intended for use in military/aerospace applications or environments unless the TI products are specifically designated by TI as military-grade or "enhanced plastic." Only products designated by TI as military-grade meet military specifications. Buyers acknowledge and agree that any such use of TI products which TI has not designated as military-grade is solely at the Buyer's risk, and that they are solely responsible for compliance with all legal and regulatory requirements in connection with such use.

TI products are neither designed nor intended for use in automotive applications or environments unless the specific TI products are designated by TI as compliant with ISO/TS 16949 requirements. Buyers acknowledge and agree that, if they use any non-designated products in automotive applications, TI will not be responsible for any failure to meet such requirements.

Following are URLs where you can obtain information on other Texas Instruments products and application solutions:

Products

Amplifiers	amplifier.ti.com
Data Converters	dataconverter.ti.com
DSP	dsp.ti.com
Clocks and Timers	www.ti.com/clocks
Interface	interface.ti.com
Logic	logic.ti.com
Power Mgmt	power.ti.com
Microcontrollers	microcontroller.ti.com
RFID	www.ti-rfid.com
RF/IF and ZigBee® Solutions	www.ti.com/lprf

Applications

Audio	www.ti.com/audio
Automotive	www.ti.com/automotive
Broadband	www.ti.com/broadband
Digital Control	www.ti.com/digitalcontrol
Medical	www.ti.com/medical
Military	www.ti.com/military
Optical Networking	www.ti.com/opticalnetwork
Security	www.ti.com/security
Telephony	www.ti.com/telephony
Video & Imaging	www.ti.com/video
Wireless	www.ti.com/wireless

Mailing Address: Texas Instruments, Post Office Box 655303, Dallas, Texas 75265
Copyright © 2008, Texas Instruments Incorporated